

- RECEPTACLE ACCEPTS A .008-.014 THICK I.C. LEAD.
- TUBE LOADED FOR AUTOMATIC INSERTION.
- $\triangle 3$  TWO .000030 MIN THK. GOLD STRIPES IN CONTACT AREA WITH TIN-LEAD (93/7) ON CONTACT LEGS, BALANCE OF CONTACT NICKEL PLATED.
- $\triangle 4$  TWO .000015 MIN THK. GOLD STRIPES IN CONTACT AREA WITH TIN-LEAD (93/7) ON CONTACT LEGS, BALANCE OF CONTACT NICKEL PLATED.

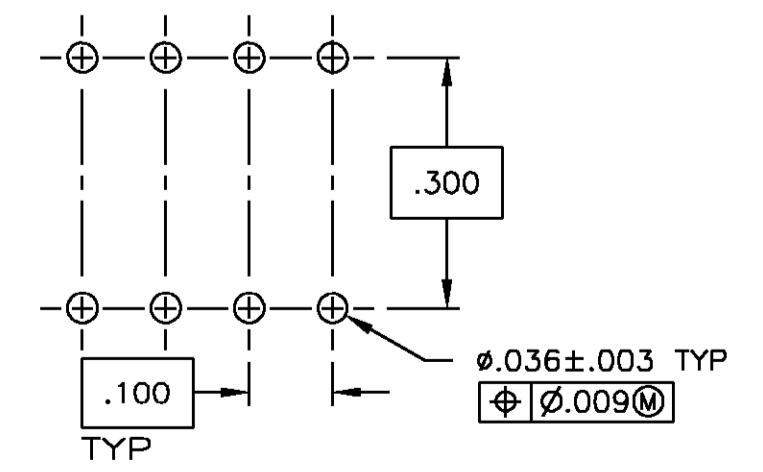
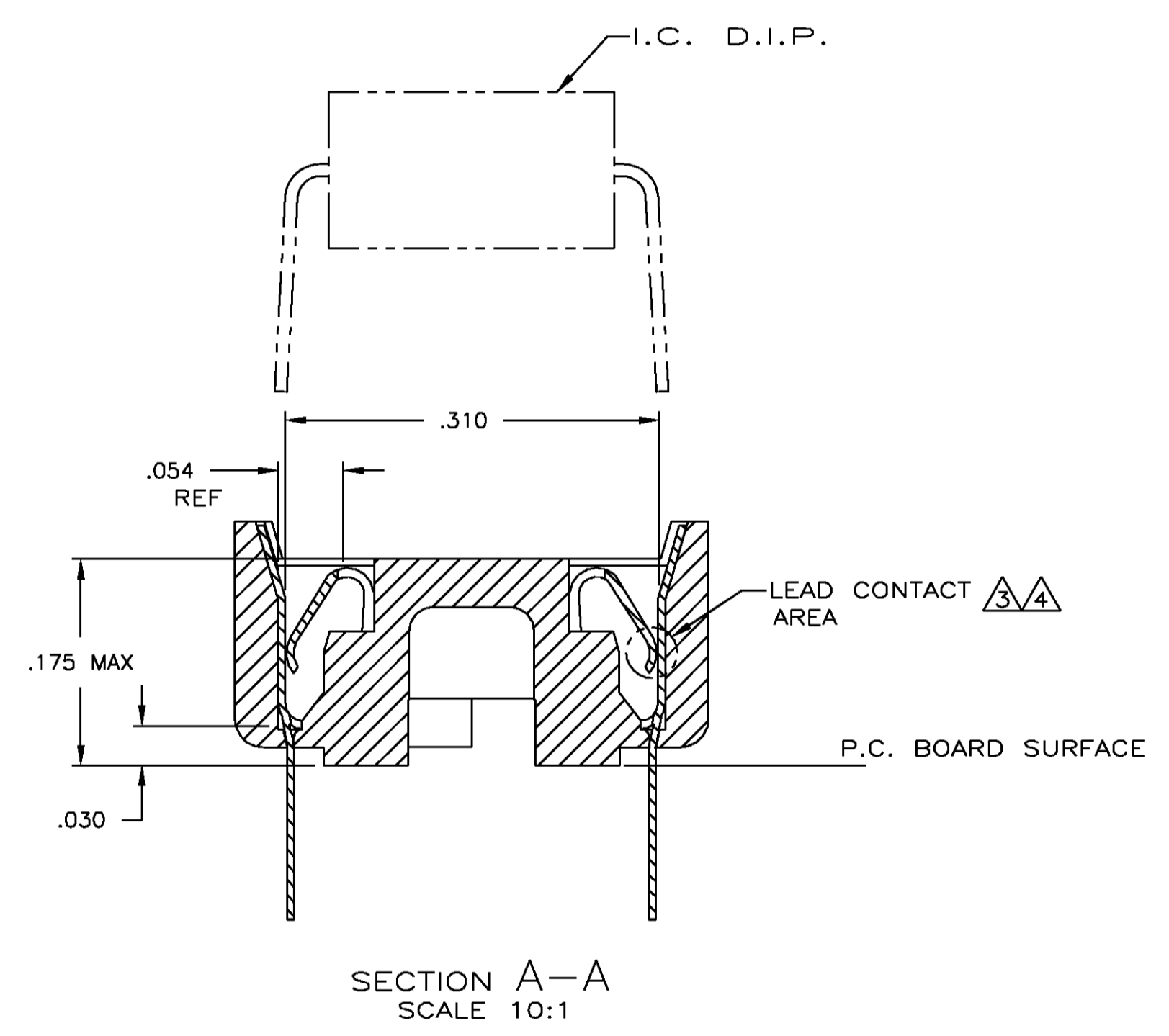
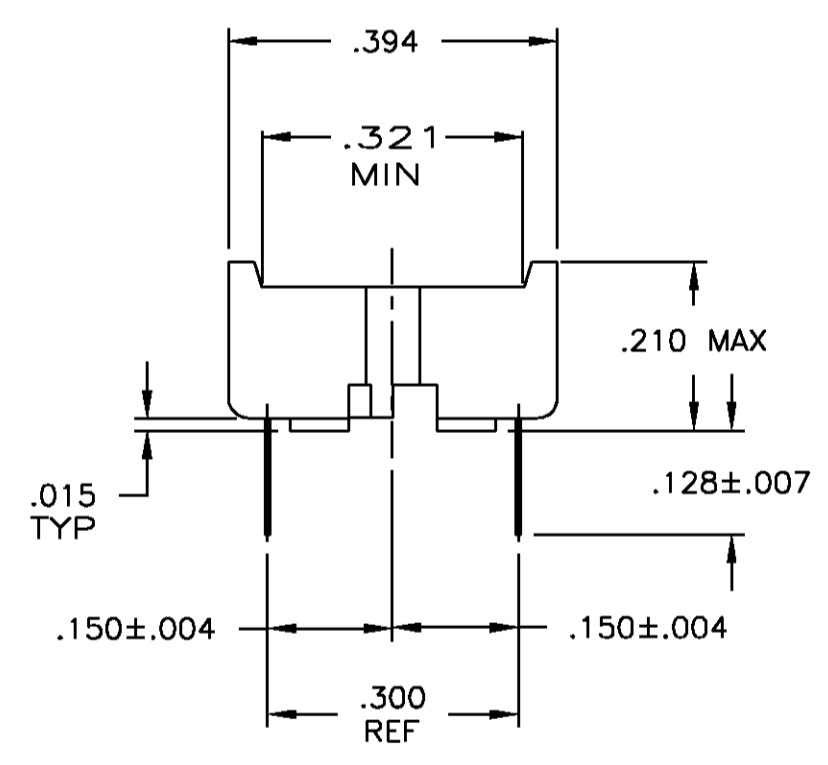
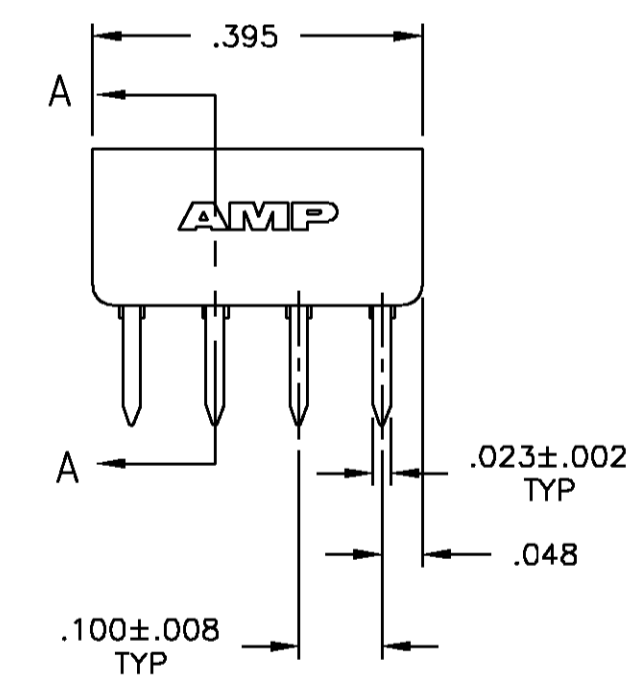
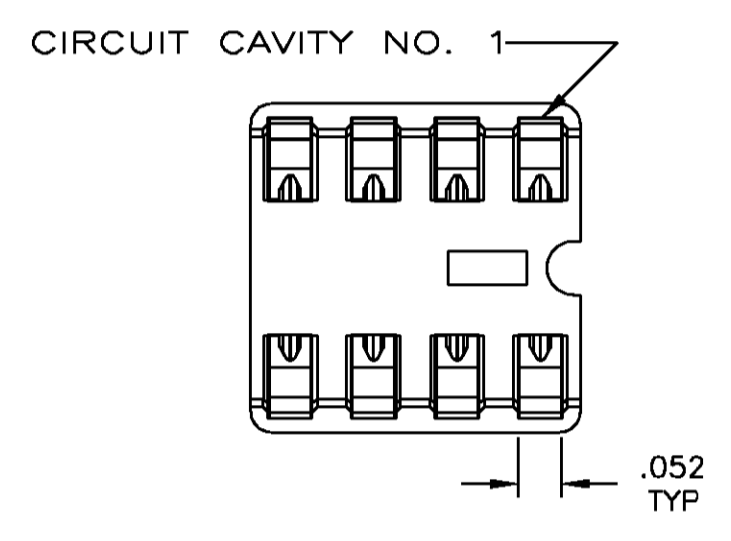

RECOMMENDED MOUNTING HOLE PATTERN  
SCALE 4:1

OBSELETE	TINNED	PHOS.BRZ. .006 THK	GLASS-FILLED THERMOPLASTIC, 94V-0, BLACK	2-640463-5
SUPERSEDED BY 390261-2	$\triangle 3$ TINNED	PHOS.BRZ. .006 THK	GLASS-FILLED THERMOPLASTIC, 94V-0, BLACK	2-640463-4
SUPERSEDED BY 390261-2	$\triangle 3$ TINNED	BE.CU. .006 THK	GLASS-FILLED THERMOPLASTIC, 94V-0, BLACK	2-640463-3
	TINNED	BE.CU. .006 THK	GLASS-FILLED THERMOPLASTIC, 94V-0, BLACK	2-640463-2
	TINNED	BE.CU. .006 THK	GLASS-FILLED THERMOPLASTIC, 94V-0, BLACK	2-640463-1

CONTACT FINISH		CONTACT MAT'L		HOUSING MATERIAL		PART NO.	
THIS DRAWING IS A CONTROLLED DOCUMENT.							
DIMENSIONS:		TOLERANCES UNLESS OTHERWISE SPECIFIED:		DRAWN		DATE	
INCHES		0 PL ± .005		M. CYRUS		2-20-87	
		1 PL ± .005		R. MILLER		2-20-87	
		2 PL ± .005		R. MILLER		2-28-87	
		3 PL ± .005		J. LAMBERT		2-28-87	
		4 PL ± .005		NAME		NAME	
		ANGLES ± .005		PRODUCT SPEC		PRODUCT SPEC	
MATERIAL		FINISH		APPLICATION SPEC		APPLICATION SPEC	
SEE TABLE		SEE TABLE		114-1049		114-1049	
				WEIGHT		WEIGHT	
				CUSTOMER DRAWING		CUSTOMER DRAWING	
				SCALE		SCALE	
				5:1		5:1	
				SHEET		SHEET	
				1 OF 1		1 OF 1	
				REV		REV	
				AF		AF	